

APPLY DRYVIT GRID TAPE™ OR TREMCO EXOAIR® 230 WITH TREMCO® 2011 MESH (SEE NOTES 1, 2, 5)

STEP #1

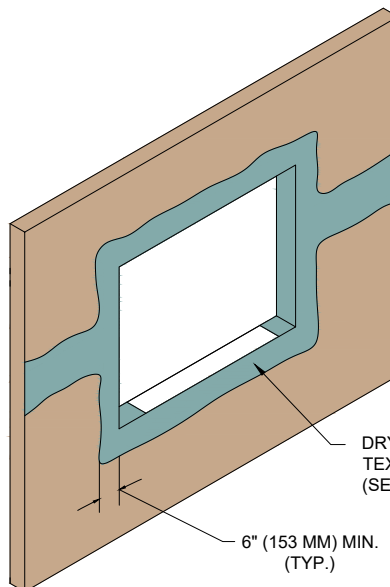

DRYVIT BACKSTOP® NTX™ - TEXTURE OR TREMCO EXOAIR 230 (SEE NOTE 2)

6" (153 MM) MIN. (TYP.)

STEP #2

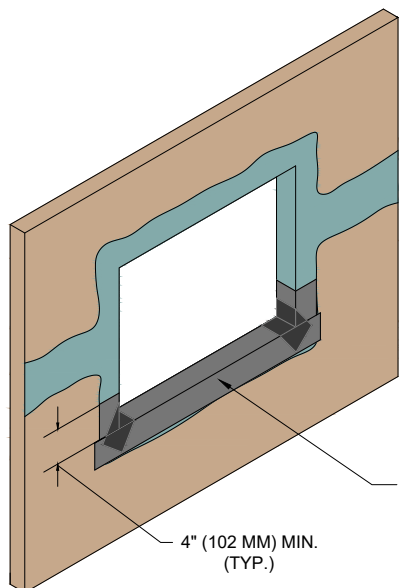

APPLY DRYVIT AQUAFLASH® SYSTEM OR TREMCO EXOAIR 230 WITH TREMCO 2011 MESH (SEE NOTES 2, 4, 5)

4" (102 MM) MIN. (TYP.)

STEP #3

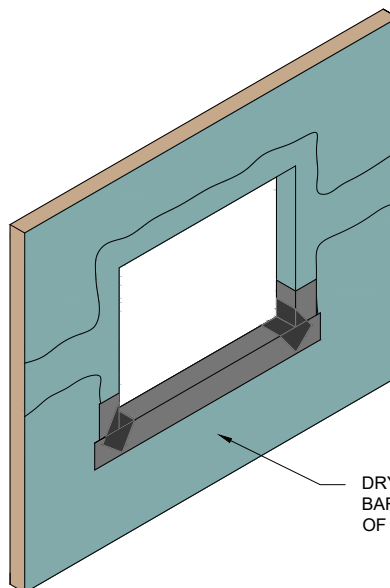

DRYVIT/TREMCO AIR/WATER-RESISTIVE BARRIER COATING APPLIED TO FACE OF WALL (SEE NOTE 4)

STEP #4

NOTE:

1. APPLY DRYVIT GRID TAPE OR TREMCO EXOAIR 230 WITH TREMCO 2011 MESH ON HEAD, JAMB, AND CORNERS OF OPENINGS AND SHEATHING JOINTS.

2. TROWEL APPLY DRYVIT BACKSTOP® NTX™ - TEXTURE OVER THE DRYVIT GRID TAPE OR APPLY TREMCO EXOAIR 230 WITH TREMCO 2011 MESH ALL THE WAY TO INSIDE FACE OF OPENING. ALL VOIDS MUST BE FILLED; MULTIPLE PASSES MAY BE REQUIRED. AS AN OPTION, DRYVIT GRID TAPE AND DRYVIT BACKSTOP® NTX™ - TEXTURE MAY ALSO BE APPLIED AT THE SILL PRIOR TO DRYVIT AQUAFLASH SYSTEM APPLICATION

3. INSTALL WINDOW UNIT AND ASSOCIATED FLASHINGS PER MANUFACTURER'S RECOMMENDATIONS, CODE REQUIREMENTS AND PROJECT DOCUMENTS.

4. REFER TO HEAD, SILL, AND JAMB DETAILS FOR FLASHING INTEGRATION.

5. REFER TO PRODUCT DATA SHEETS FOR SPECIFIC APPLICATION METHODS.

The architecture, engineering, and design of the project using the Dryvit and Tremco products are the responsibility of the project's design professional. All products and systems must comply with local building codes and standards. This detail is for general information and guidance only and Dryvit and Tremco specifically disclaims any liability for the use of this detail. The project design professional determines, in its sole discretion, whether this detail or a functionally equivalent detail is best suited for the project. This detail is subject to change without notice. Contact Dryvit and Tremco to ensure you have the most recent version.

StucCoat One Coat® System



Dryvit Technical Support: 800-556-7752

Detail: Opening Preparation - Backstop® NTX or Tremco ExoAir® 230 Option

Drawn by: KAB

Checked by: BD/CB

Scale: NTS

Date: 4/2023

File Name:

SCOC CI 5



Construction Products Group

www.tremcocpg.com